

INSTALLATION INSTRUCTIONS

2013-2018 G3 Full / Front Enclosure / Double Canopy

V322 FC & V22 FC

PARTS LIST

1 Bow canopy frame (Figure 3)	BOW HARDWARE PACKAGE
1 Bow canopy	2 "H" Brackets (1 ¼")
1 Bow canopy boot	4 ¼"-20 barrel nuts
1 Aft curtain	2 ¼"-20 shoulder bolts
1 Aft canopy with zippers	2 Deck buttons with ¼"-20 x 1.5" bolt
1 Aft canopy boot	2 5/16"x2" bolts
2 Aft side curtains (1 port, 1 starboard)	2 Lock washers
2 Bow side curtains (1 port, 1 starboard)	2 5/16" Tri wing knob
2 Aft side extension curtains (1 port, 1 starboard)	4 Plastic shoulder washers
1 Extended aft frame (Figure 4)	8 Self-drill screws
1 Extended aft canopy	AFT HARDWARE PACKAGE
2 Bow curtains (1 port, 1 starboard)	4 ¼"-20 barrel nuts
1 Bow hardware package	4 Deck buttons with ¼"-20 x 1.5" bolt
	8 Self-drill screws

TOOLS REQUIRED

Measuring Tape
Center Punch
Drill
5/16" Drill Bit
Pencil
Phillips Screwdriver
2 Sets SAE allen wrenches



WARNING

INDICATES POTENTIAL HAZARD THAT COULD RESULT IN DEATH OR INJURY



CAUTION

INDICATES POTENTIAL HAZARD THAT COULD RESULT IN BOAT DAMAGE



NOTE

INDICATES SPECIAL INFORMATION TO MAKE MAINTENANCE EASIER OR INSTRUCTIONS CLEARER



NOTE:

This enclosure is designed to fit the 2013 G3 V(3)22 Fish Cruise Pontoon Boat that has the aft canopy brackets in the following locations:
 Main Bracket from rear fence 77.5" Rear HDA 33.5" FWD HDA 16.25"

Measurements should be taken from the main bracket of the aft canopy bracket as shown below for bow and extended aft canopy brackets/hinges.

If the brackets are off more than 1-inch in either direction, the enclosure WILL NOT FIT.

All measurements are taken to the center of the brackets.

FIG. 1

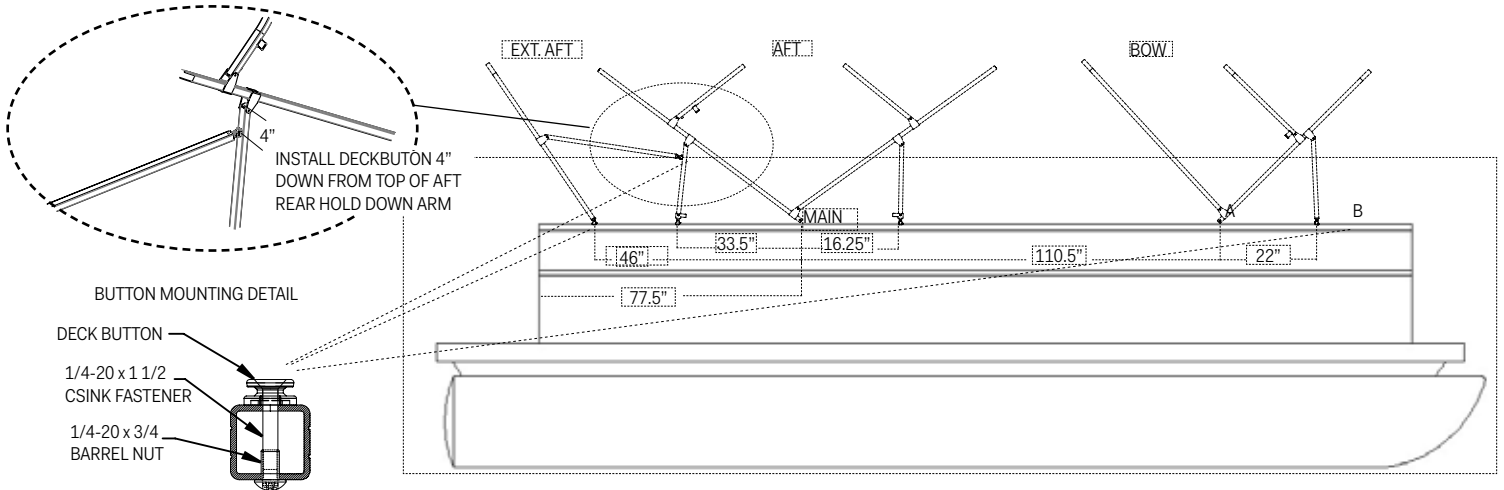

NOTE:

Your pontoon has been pre-assembled with an aft canopy and aft canopy frame from G3. The aft canopy that is supplied with the pontoon is not designed to be used with an enclosure. You must remove the standard aft canopy and replace it with the aft canopy that is supplied with the purchase of your enclosure. Once the new canopy is installed, raise the entire unit to the "up" position. Make sure the aft canopy is centered on the frame between the port and starboard sides. This step is very critical, it will determine the final appearance of your completed enclosure.

BRACKET LOCATIONS & ASSEMBLY (FIGURES 1 & 2)

STEP 1

Bracket location (A). Measure and place a mark on the top rail 110" forward from aft main bracket. Button location (B). Measure and place a mark on the top rail 22" forward from (A).

STEP 2

Center the brackets/buttons at each mark as shown in Figure 2. Transfer the centers of each hole at the bottom of the bracket on to the rail using a center punch.

STEP 3

Using 5/16" drill bit, drill holes completely through the top rail.

STEP 4

Replace the brackets. Insert a 1 3/4" bolt from the top through the bracket and the rail. Place a barrel nut on each bolt and tighten (Figure 2).

STEP 5

Follow the same procedure for the other side.

FIG. 2

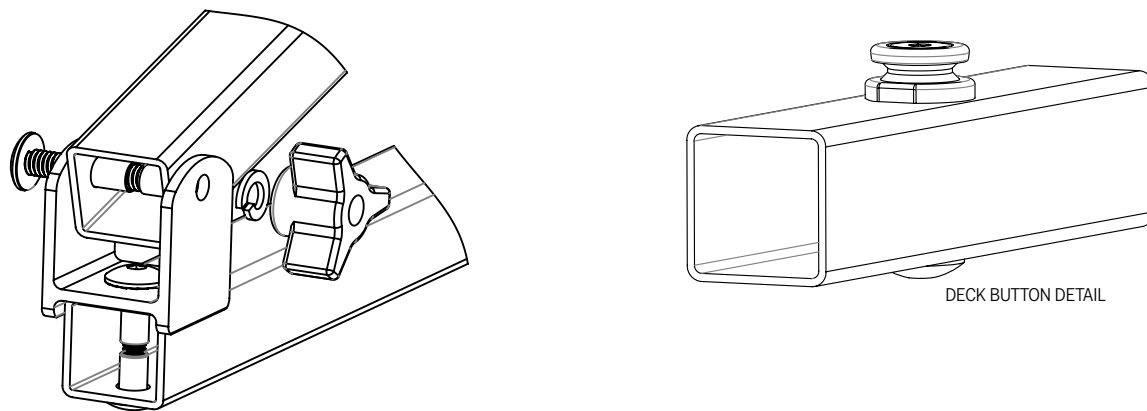

CAUTION

TO PREVENT DAMAGE TO THE TOP RAIL, IT IS RECOMMENDED TO DRILL A PILOT HOLE FIRST.

FIG. 3

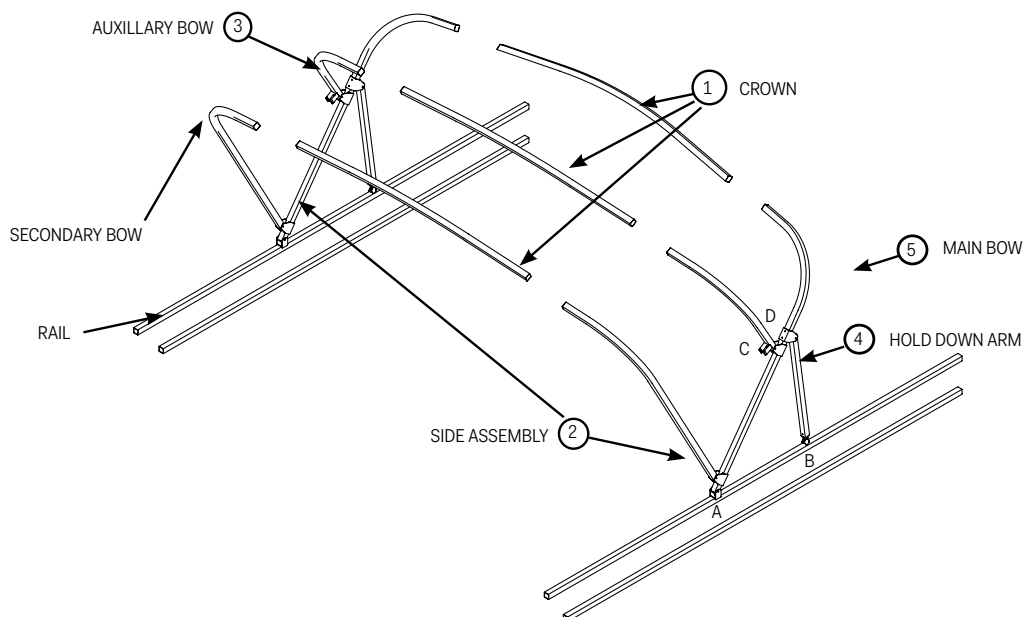

BOW CANOPY & BOW CANOPY FRAME ASSEMBLY (FIGURE 3)

STEP 1

Insert crown pieces (1) into side assemblies (2), making sure that the bend in the center of the mid-frame is to the top following the curve of the frame.

STEP 2

After each side assembly has been inserted into each crown piece, secure each split with the provided 1/2" self-drilling screws by drilling through the crown into the stakes of the side assemblies.

STEP 3

With two people, take the bow frame assembly onto the boat and insert the main bow tube into the previously installed bow H bracket (A). Using two provided 5/16"x2" bolts, lock washers and tri-wing knobs secure the frame to the rail (Figure 2).

STEP 4

Once the frame is secure, raise the assembly up and latch the hold-down arm (4) to the deck buttons (B) (Figure 2).

STEP 5

Lay the secondary and aux bows toward the aft of the boat. Zip the front pocket of the bow canopy to the main bow (5). Release the hold-down arms (4) and zip the bow canopy to the aft canopy. Push up the aux bow and zip to pocket - push the secondary bow up and zip to pocket.

STEP 6

Center the bow canopy at this time before securing the hold-down arm (4) to the pontoon. Place end of hold-down arm (4) into bracket (B).

STEP 7

Move to the installation of the extended aft frame/canopy (Figure 4).

FIG. 4

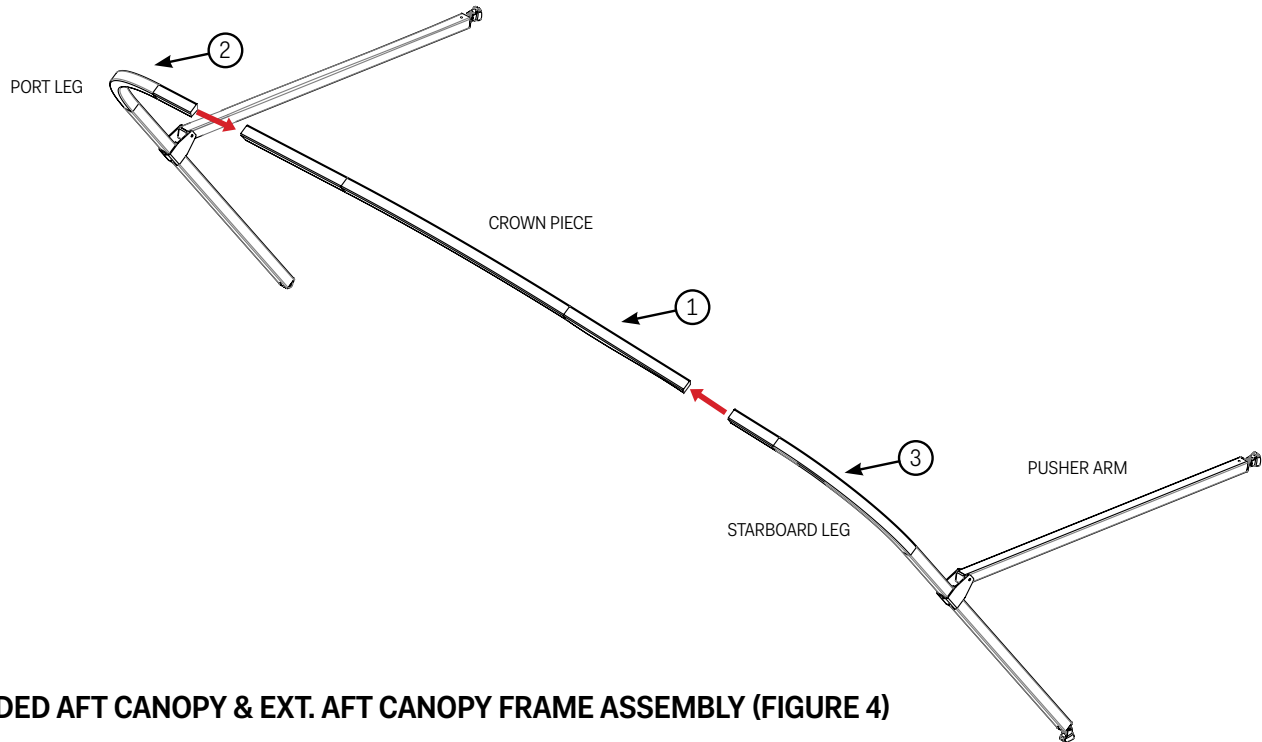
**EXTENDED AFT CANOPY & EXT. AFT CANOPY FRAME ASSEMBLY (FIGURE 4)****STEP 1**

Insert crown piece (1) into the port leg (2) and starboard leg (3) making sure that the bend in the center of the crown is to the top following the curve of the frame.

STEP 2

At this time, you can fix the frame at the split location by using the #8 self-drilling screw provided.

STEP 3

With two people, the frame can now be attached to the boat and deployed using the pusher arms.

STEP 4

Once the frame is up, the extended aft canopy can be installed on the frame.

1. Zip the pocket onto the bow first
2. Release the pusher arms
3. Pull the extended aft canopy zippers to the aft canopy zippers and zip together
4. Center the extended aft canopy
5. Engage the pusher arms

CURTAINS (FIGURE 5)**STEP 1**

Each curtain has a tag sewn in the upper left-hand corner of the flap. This will identify each curtain and give its location on the pontoon.

STEP 2

The curtain flaps will face the inside of the pontoon.

STEP 3

Zip all curtains to both canopy tops.

STEP 4

Zip all curtains together.

STEP 5

Leave the bottom of the curtains draped over the pontoon rails

STEP 6

Make sure the bottom of the curtains are hanging the same length on both sides of the pontoon. This is where centering both of the canopy tops is very important. If the curtains are uneven, you may have to remove all the curtains and re-center one or both canopy tops.

FIG. 5

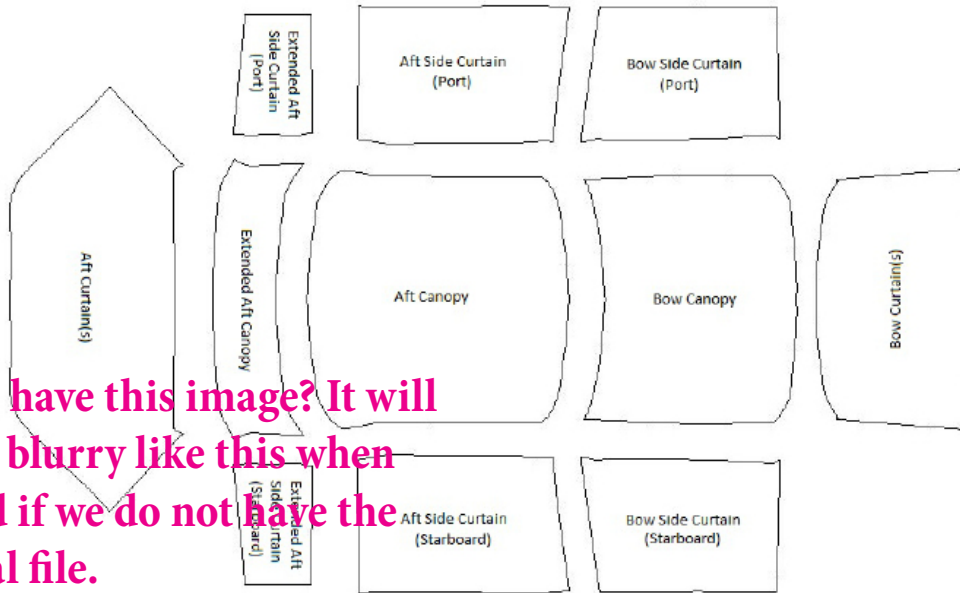

Do you have this image? It will appear blurry like this when printed if we do not have the original file.

INSTALLING SCREW STUD FASTENERS (FIGURE 5)

STEP 1

Make sure all the curtains are zipped together.

STEP 2

Start with the aft side curtains. Make sure the lower front corner of both curtains hang the same distance from the door opening. Mark the location of the nearest snap (A) on the aluminum rail and install stud.

STEP 3

Find the last snap (B) on the same side. You may have to adjust the curtain bottoms by pulling the curtains taut so they appear smooth along the rail. You do not want the curtains to appear (wav). Mark and install the stud.

STEP 4

Find the first snap (C) on the same side. Install the remaining studs.

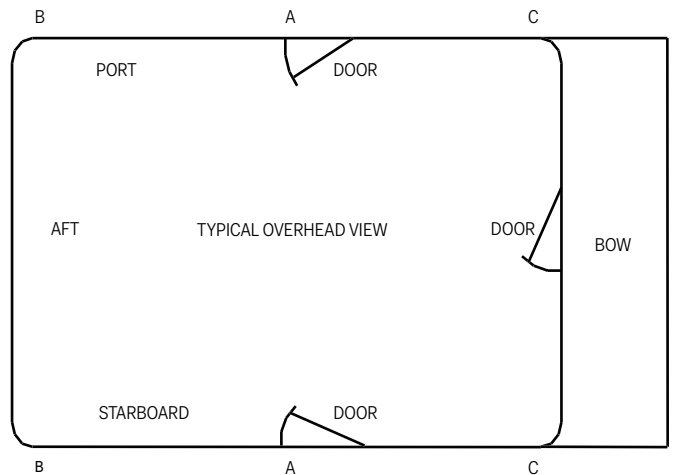

CARE



WARNING

DO NOT TRAILER BOAT WITH ANY CANOPY TOP UP (IN RADAR ARCH POSITION) OR WITH THE ENCLOSURE ASSEMBLED!